

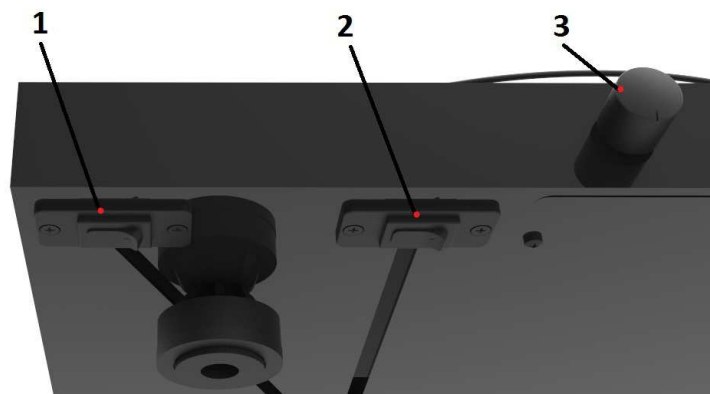

INSTRUCTIONS FOR USE
Pro-Ject Jukebox S2

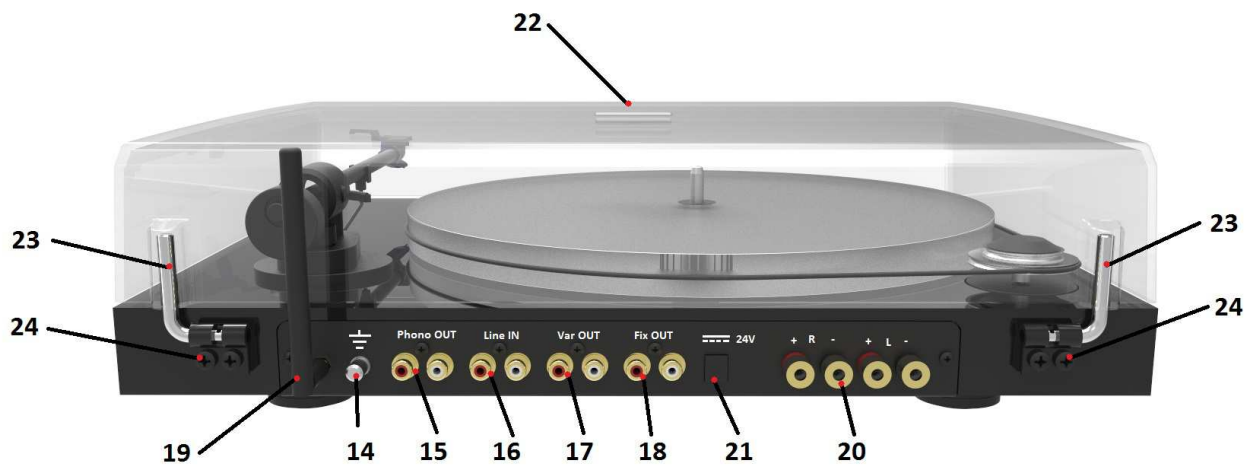
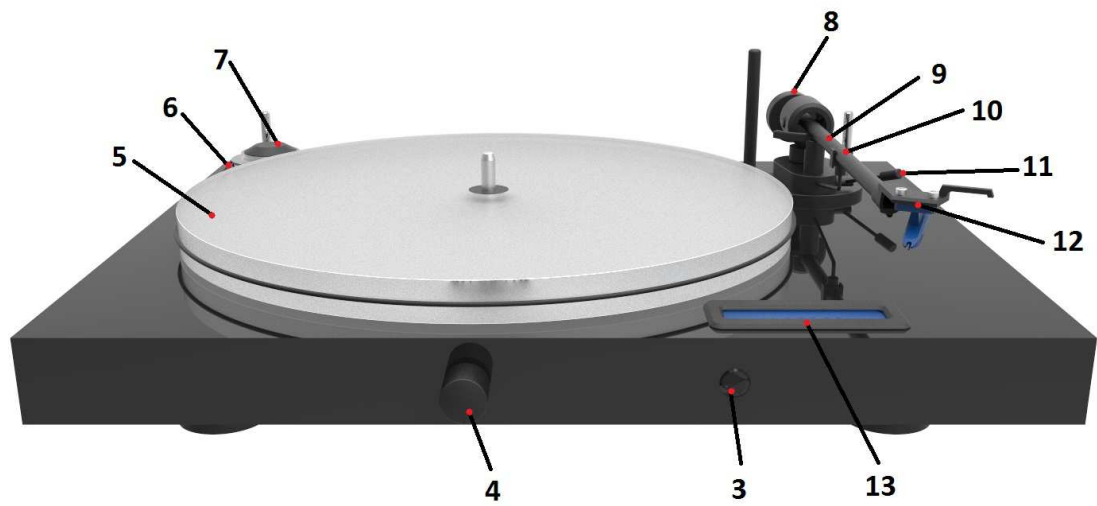

Controls, features and connections

- (1) TURNTABLE MOTOR SWITCH
 - (2) AMPLIFIER ON/OFF SWITCH
 - (3) REMOTE CONTROL
 - (4) INPUT SELECTOR, VOLUME CONTROL
 - (5) PLATTER
 - (6) DRIVE BELT
 - (7) STEPPED DRIVE PULLEY
 - (8) TONEARM COUNTERWEIGHT
 - (9) TONEARM TUBE
 - (10) TONEARM REST AND REMOVABLE TRANSPORT LOCK
 - (11) TONEARM LIFT LEVER
 - (12) HEADSHELL WITH FINGER LIFT
 - (13) TURNTABLE DISPLAY
 - (14) EARTH CONNECTION
 - (15) PHONO OUT
 - (16) LINE IN
 - (17) VAR OUT
 - (18) FIX OUT
 - (19) BLUETOOTH ANTENE
 - (20) SPEAKERS OUTPUT
 - (21) POWER SUPPLY SOCKET
 - (22) LID
 - (23) LID HINGE
 - (24) HINGE FASTENERS
- POWER SUPPLY (NOT SHOWN) *

Dear music lover,

Thank you for purchasing a record player from Pro-Ject Audio Systems.

In order to achieve maximum performance and reliability with this record player you should study these instructions for use carefully.



Warning of a hazard for the user, the unit or possible misuse



Important notice

The following instructions for adjusting the cartridge are provided in case the cartridge is replaced by a different model at a later date.

During assembly and adjustment of the deck small parts could be lost if not carefully placed in a suitable receptacle. Before starting assembly make get familiar with the parts listed above and correspondingly numbered in the technical drawings above. Separately packed items are marked with an asterisk *.

Safety instructions

The power supply is used to connect and disconnect the unit from the mains. Make sure that the plug is easily accessible at all times. Hold the plug when unplugging the power cord. Never handle the power cord while your hands are wet or damp.



Avoid letting liquids enter the device. Never place any item containing liquid, like a flower vase, on or near the device. Never spill any liquid on the device. Never place any naked flame sources, like lighted candles, on or near the device. The product shall not be used in damp or wet locations, next to a bathtub, sink, swimming pool or any other similar conditions.

Keep plastic bags away from children to prevent any risk of suffocation.

Platter and drive belt installation

Please remove brown paper insert which holds the platter in transport position. Put the felt mat on the top of the platter. Install the drive belt as shown in the following illustration.

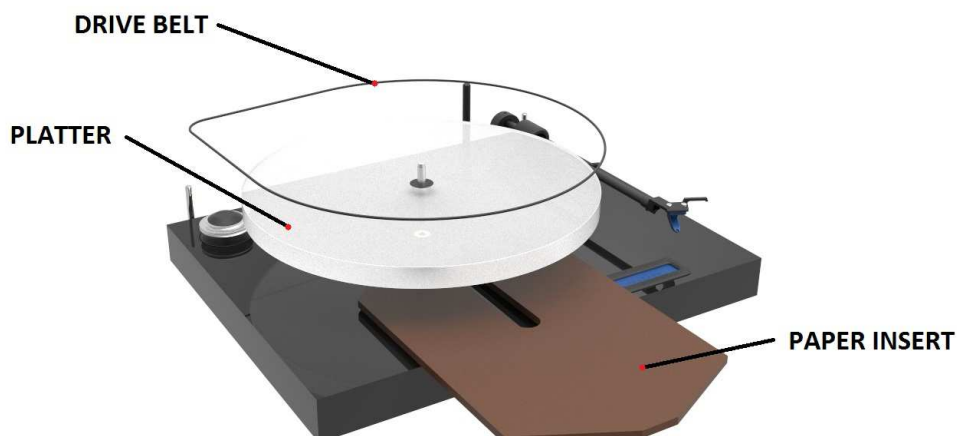

Cartridge downforce adjustment

The counterweight (8) supplied is suitable for cartridges weighing between 3 - 7g (weight no. **81**). The counterweight is pre-set perfectly from the factory.

In case you need to set the tracking force, please read following instructions:

Place the stylus pressure gauge onto the platter. To adjust the amount of pressure, carefully move the counterweight along the support rod, until the stylus pressure is sufficient to raise the pressure gauge to the level position. Moving the counterweight away from the cartridge will reduce pressure and towards will increase pressure. Finally secure the counterweight using hexagonal key provided.

If the stylus gauge becomes level, then the correct pressure has been achieved. However if there is insufficient or excessive pressure the gauge will either not move or tilt down.

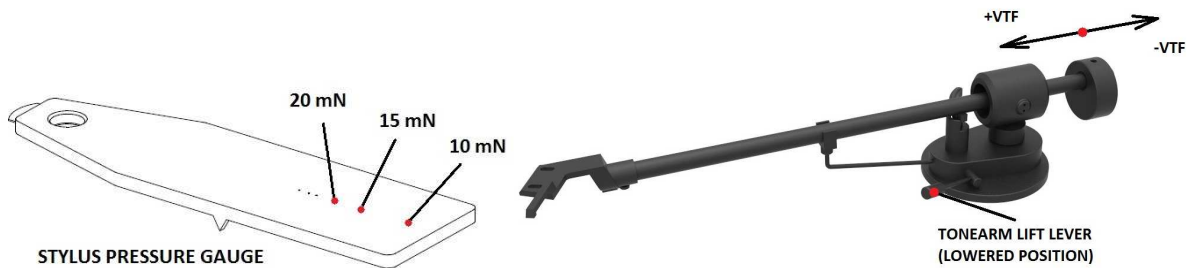

Connectors



Take care to connect the left and right channels correctly. The right channel is usually marked red, the left channel black or white.

The red speaker terminals carry the positive signal (+), the black speaker terminals the negative signal (-). Make sure the polarity of the connection is correct at each end of the cables.

Connection to the speakers

The output terminals accept loudspeaker cables terminated with 4mm Ø Banana plugs, spades connectors or naked wire.

Variable output (Line output)

A power amplifier or active loudspeakers can be connected to the output sockets marked **Var Out (17)**.

Fixed output (Record output, connecting a headphone amplifier)

Fix Out (18) connects an analogue record device or a Pro-Ject Head Box headphone amplifier.

Phono output

To use an external phono preamplifier, connect the RCA sockets marked **Phono OUT (15)**. The earthing wire may be connected to the screw terminal if you encounter hum problems when using the turntable.

Line input

Line level sources such as CD player, radio or TV can be connected to the input sockets marked **Line IN (16)**.

Mains power connection

Connect the low voltage plug from the power supply to the **24V socket (21)** before connecting the power supply to the mains.

Switching ON and OFF (turntable motor)

The rocker switch (1) on the bottom turns the motor of the turntable

To switch on from standby or to standby (amplifier)

The rocker switch (2) on the bottom turns the unit on or back into standby.

Control of the unit using the knob on the front

Standby

After the unit is powered on by the rocker switches on the bottom, pressing the knob for 3 seconds, turns the unit on. For turn the unit back to standby press the knob again for 3 seconds



It is important to turn the unit to standby before it's powered off by the switch on the bottom. To not follow this step may cause damage to the speakers.

Input selector

After the unit is turned on, pressing the button in the middle selects desired input. After start Bluetooth input is always selected. Pressing input button changes inputs in following order: Bluetooth > Turntable > Line In. Bluetooth input gives a "beep" sound when selected. Selected input is indicated on the top line of the display.

Volume

Adjust the volume to the desired level rotating the knob. Volume can be set in 33 steps (0-32) and is indicated on the bottom line of the display

Remote control



red button turns the unit on or back into standby

Mute activate/deactivate mute

Bass+/Bass-/Treble+/Treble- tone control

Loudness activate/deactivate Loudness

Bluetooth/Turntable/Line in direct access to input

Volume+/Volume- adjust volume

Bluetooth connection



Bluetooth is active only when Bluetooth input is selected.

Juke Box E remembers last paired unit and reconnects automatically when available and if the bluetooth device allows automatic reconnections.

Juke Box E doesn't request any pairing code confirmation.



Only one active Bluetooth connection is possible at a time. If the unit can't be found in Bluetooth search window in mobile device, make sure that there is no other active Bluetooth connection.

Bluetooth input gives 2 different "beeps",

First appears when Bluetooth input is selected. And in case of Bluetooth device disconnects.

Second appear when Bluetooth device is found and connected.

Pairing with Android devices

Open **Settings** and tap on **Bluetooth**. Turn on Bluetooth and tap on **Scan**. Searched devices will show up. Tap on "**Juke Box E**".

Pairing with Apple devices

Tap on **Settings**, tap on **Bluetooth**, turn on Bluetooth. Your device will automatically start searching for available devices. Tap on "**Juke Box E**".

Fitting the lid

Fit the lid (dust cover) carefully over the lid hinges (23) and adjust the screws (24) until the lid stays open where you want it to without being too stiff to open or close.

Changing replay speed

Put the belt (6) over the larger diameter part of the motor pulley (7). To revert to 33 r.p.m. repeat the proceedings using the smaller step on the pulley.



For detailed product information please refer to the Pro-Ject web site www.project-audio.com.

Maintenance and cleaning

Your record player requires little or no regular maintenance. Remove dust with a slightly moistened antistatic cloth. Never use a dry cloth because this will create static electricity which attract more dust! Antistatic cleaning fluids are available at specialist stores but must be applied sparingly to avoid damage to rubber parts. It is recommended to fit the needle cover before cleaning or maintenance is carried out to avoid damage.

If the player is not used over a long period of time the drive belt can be removed to prevent unequal stretching.



Always disconnect the record player from the mains power supply as a precaution before maintenance!

Mounting and connecting the cartridge

** All cartridges with half inch mounting holes can be fitted. Leaving the needle's protection cover on, fit the cartridge to the headshell (12) using the screws supplied with the cartridge by passing one screw through each slot in the headshell (12). Do not tighten the nuts yet.

Connect the tonearm wires to the cartridge pins as follows:

white	left channel positive (L+)
red	right channel pos. (R+)
green	right channel return (R -)
blue	left channel return (L -)

The full sound quality of the record player can only be achieved if the cartridge is correctly adjusted. Particular tools like the Pro-Ject alignment tool "Align IT" are required to accomplish this job properly.

If you are not well acquainted with the adjustment of cartridges you are advised to call upon the willing help of your Pro-Ject dealer to accomplish this task for you.



Please note: Adjusting a cartridge and tonearm calls for the greatest care in order to avoid damaging the cartridge or tonearm bearings. Leave this work to your dealer if you are in any way unsure of the necessary steps and precautions to be taken.

Useful tips

The record player should be positioned on a low-resonance surface such as wood or multiple layer ply board to avoid structural vibrations disturbing replay.

Technical specifications Pro-Ject Jukebox S2 / Pro-Ject 8.6 E

Turntable

Nominal speeds	33/45 r.p.m.
Speed variance	33: $\pm 0,80\%$ 45: $\pm 0,70\%$
Wow and flutter	33: $\pm 0,29\%$ 45: $\pm 0,27\%$
Signal to noise	-65dB
Effective tonearm mass	8,0g
Effective tonearm length	8,6" (218,5mm)
Overhang	22,0mm

Amplifier

Power output	2 x 50W at 4 ohms
SNR	-75dB
Volume control	32 step
THD +N	0,5% at 1kHz, RL = 8 ohms, P = 1W
Crosstalk	-80 dB
Phono amplifier	Moving magnet (MM)
Phono gain:	43dB
Line level inputs	2 pairs RCA
Amplifier gain	32 dB
Bluetooth	2.1 + EDR
Treble equalizer	+ - 12dB
Bass equalizer	+ - 12dB

General

Replacement battery remote control	2 x AAA
Power consumption	4,5W
Outboard power supply	24V/4A DC
Dimensions (W x H x D)	415 x 118 x 334mm
Weight	5,0kg
Dimensions packaging (W x H x D)	488 x 235 x 393mm
Weight incl. packaging	7kg

Potential incorrect use and fault conditions

Pro-Ject turntables are manufactured to the highest standards and undergo strict quality controls before leaving the factory. Faults that may possibly occur are not necessarily due to material or production faults but can sometimes be caused by incorrect use or unfortunate circumstances. Therefore the following list of common fault symptoms is included.

The platter doesn't turn although the unit is switched on:

- The unit is not connected to the mains power supply.
- No mains at the socket.
- Drive belt is not fitted or has slipped off.

No signal through one or other channel or both channels:

- No signal contact from the cartridge to the internal tonearm wiring or from that to the arm lead or from that to the phono box or between that and the amplifier. This could be due to a faulty plug, broken wire or solder joint or simply loose plug/socket connection.
- Phono input not selected at amplifier.
- Amplifier is not switched on.
- Amplifier or speakers are defective or muted.
- No connection to the loudspeakers.

Strong hum on phono input:

- No earth connection from cartridge or arm or arm cable to amplifier, or earth loop.

Distorted or inconsistent sound from one or both channels:

- Record player is connected to wrong input of amplifier, or MM/MC switch incorrectly set.
- Needle or cantilever damaged.
- Wrong r.p.m., drive belt overstretched or dirty, platter bearing without oil, dirty or damaged

Service

Should you encounter a problem which you are not able to alleviate or identify despite the above information, please contact your dealer for further advice. Only when the problem cannot be resolved there should the unit be sent to the responsible distributor in your country.

Guarantee repairs will only be affected if the unit is returned correctly packaged. For this reason we recommend keeping the original packaging.

Never return a record player without making sure that it is safely disassembled and correctly packaged in the original packaging according to the diagrams on the last page of this user guide. Please remove these parts and pack them separately: lid, counterweight (4), anti-skating weight (10) and belt (22).

Fit the cartridge protection cap and the transport lock for the tonearm tube (66), prior to carefully packaging the record player.

Warranty



The manufacturer accepts no responsibility for damage caused by not adhering to these instructions for use and/or by transportation without the original packaging. Modification or change to any part of the product by unauthorized persons, release the manufacturer from any liability over and above the lawful rights of the customer.

Pro-Ject Audio Systems is a Registered Trademark of H. Lichtenegger.

This guide was produced by: Pro-Ject Audio Systems
Copyright © 2018. All rights reserved.

The information was correct at the time of going to press. The manufacturer reserves the right to make changes to the technical specification without prior notice as deemed necessary to uphold the ongoing process of technical development.

